

SPECIFICATIONS	
WEIGHT	176.9 KG (390 LBS)
ELECTRICAL	UNIVERSAL INPUT, 100V TO 240V VAC, 50/60 Hz POWER CONSUMPTION: 1500W (VA) MAX
AIR FEED	5 CFM/80 PSI OF CLEAN, DRY AIR
PASS – THROUGH	UP TO 127 MM (5")
BAG THICKNESS	27 µM – 100 µM (1.09 – 4.0 MIL)
BAG SIZES	WIDTH: 50MM – 300 MM / LENGTH 130 MM – 500 MM
WEIGHT CAPACITY	UP TO 2.25 KG (5 LBS) WITH LOAD SHELF

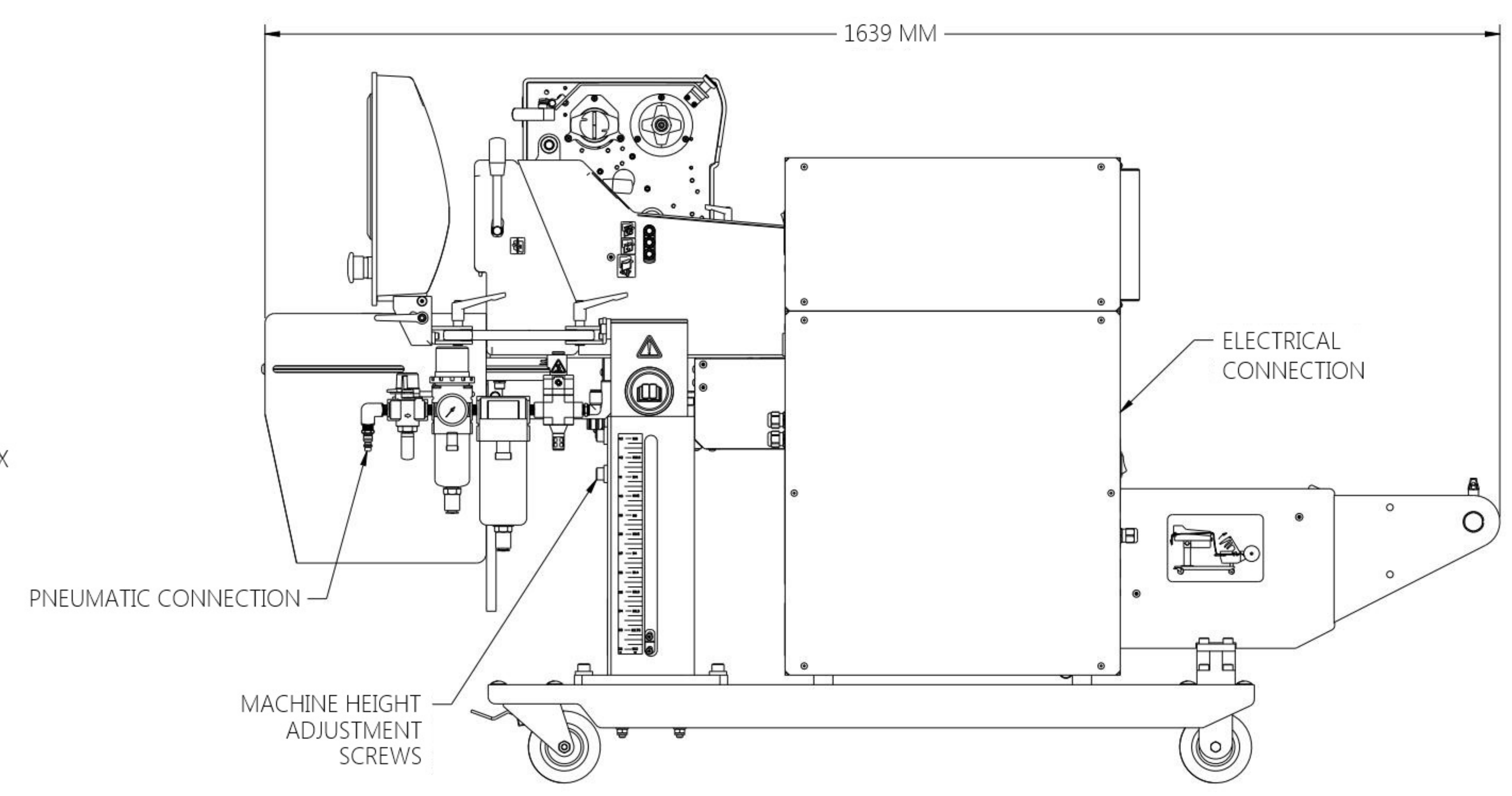
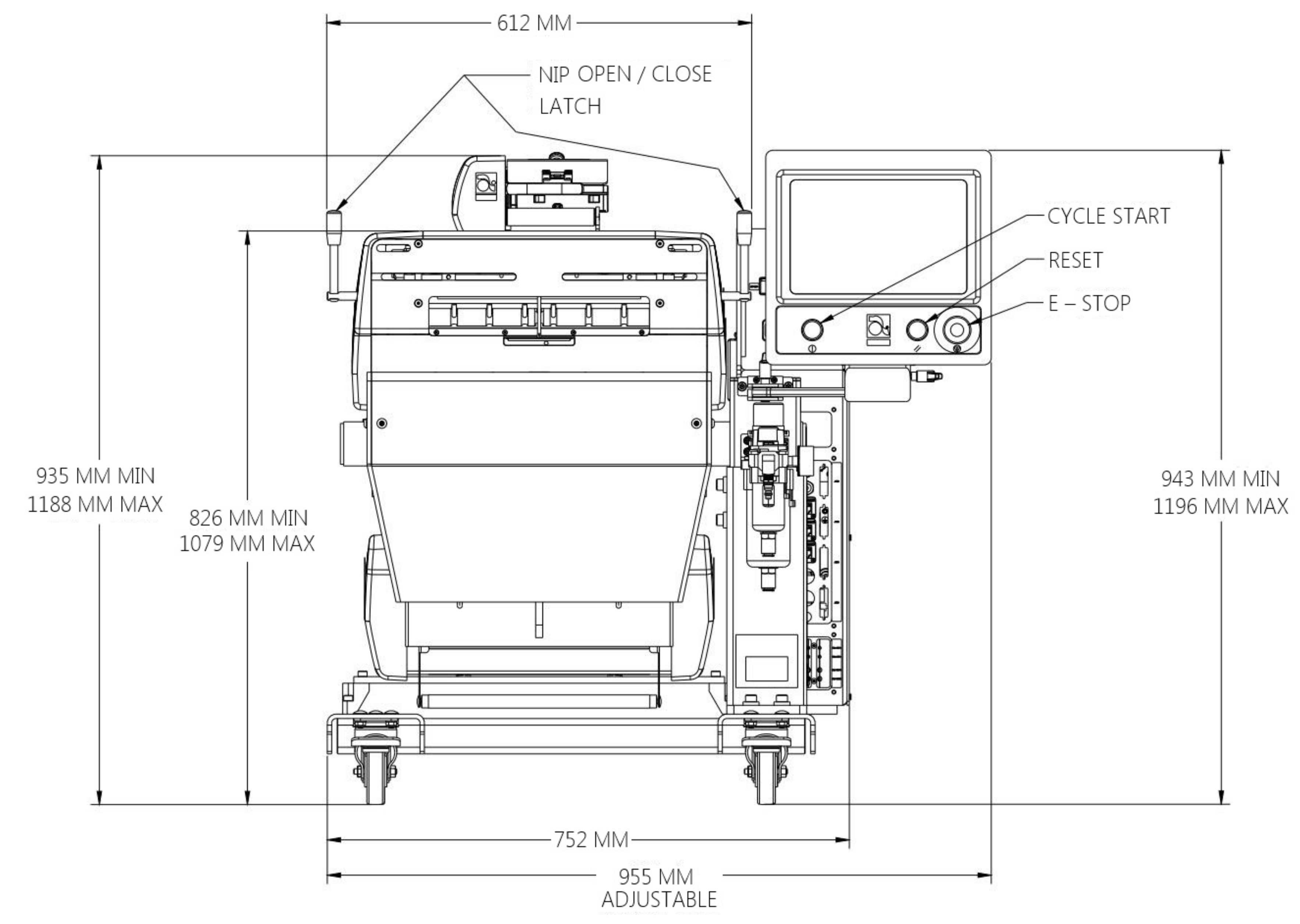
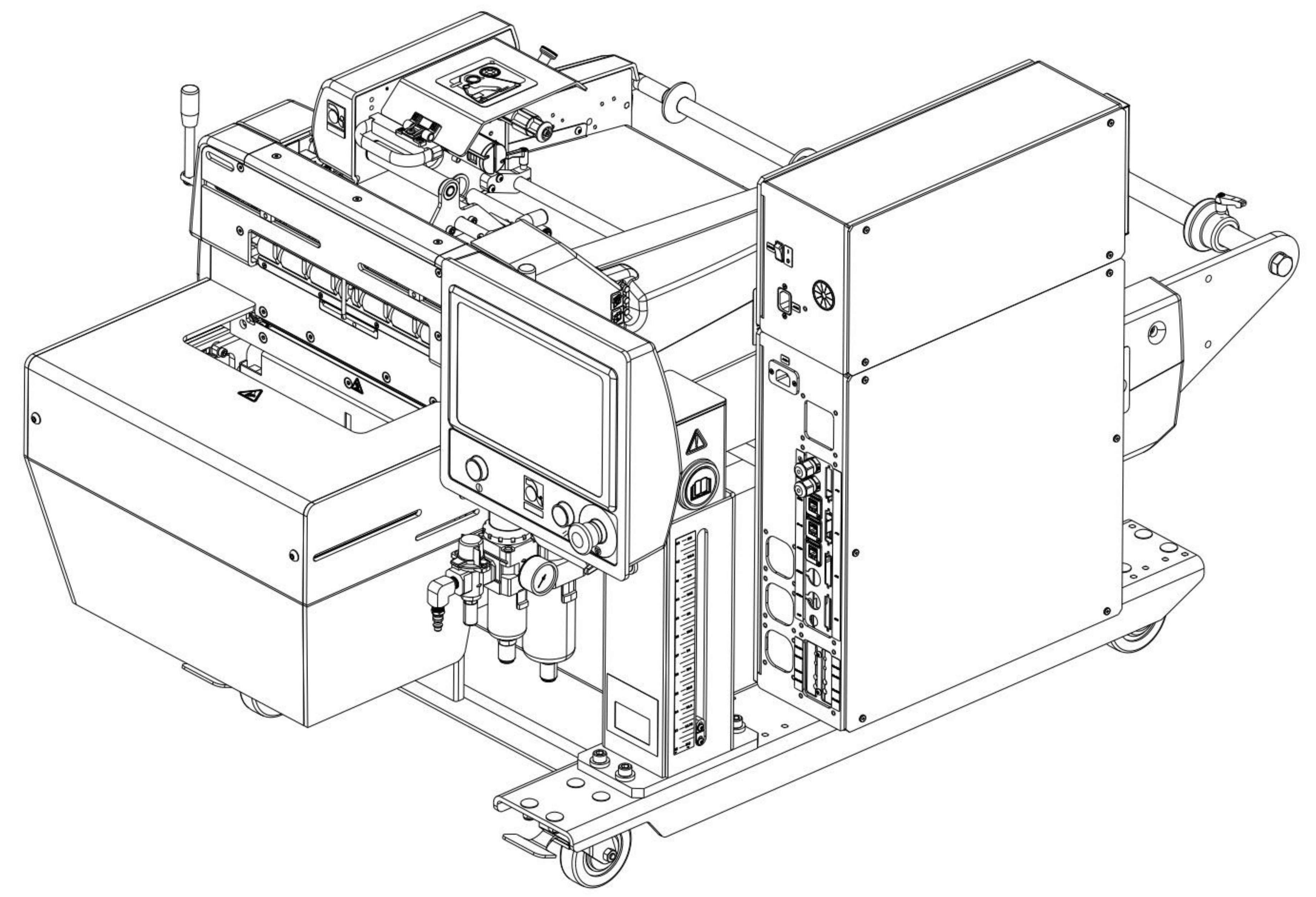
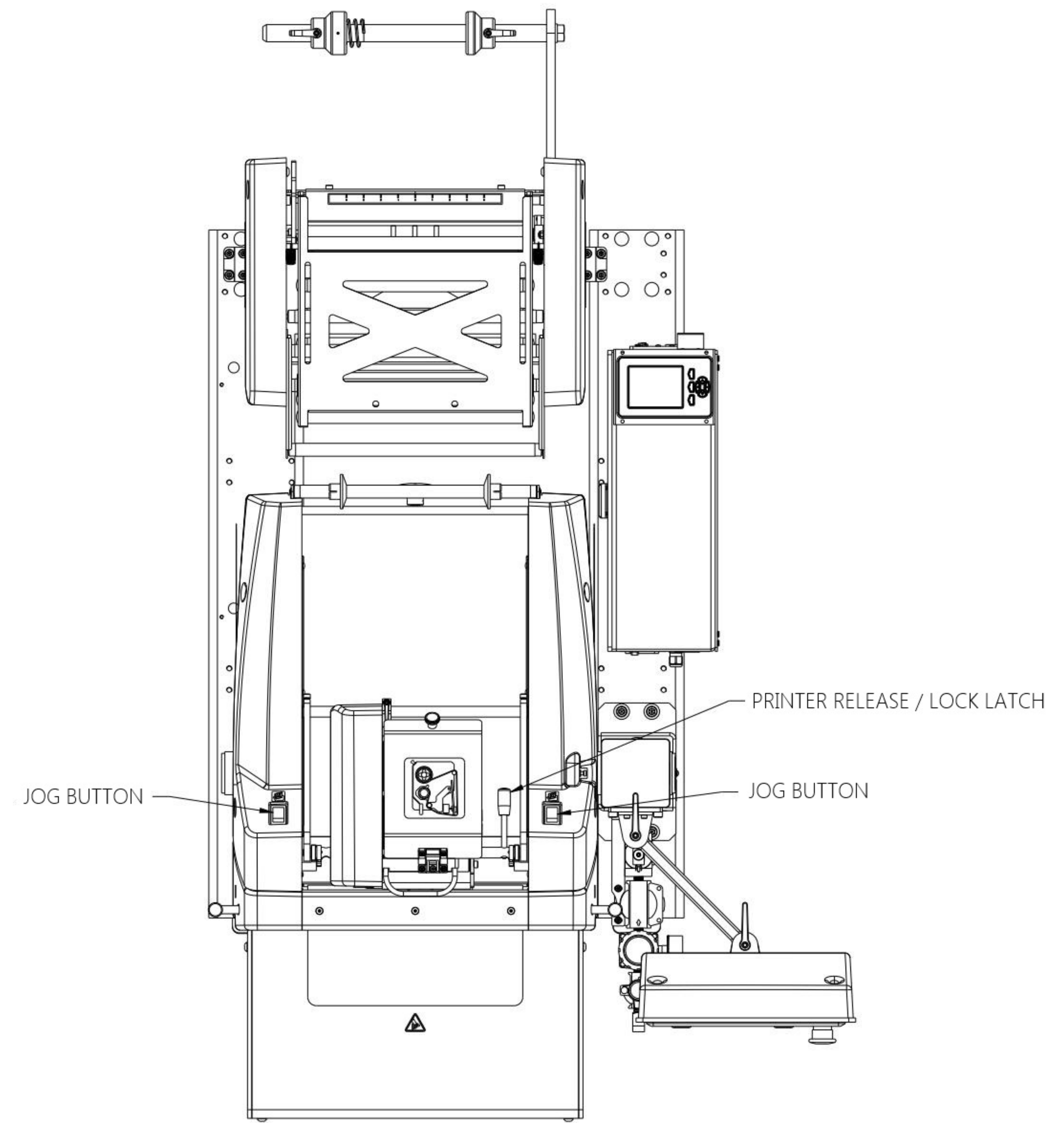

Fabricated & Documented to be RoHS Compliant

FINISH	NONE
MATERIAL	ALUMINUM 6061-T6
SCALE	1/4"
DATE	10-11-18
BY	DMF
ECN	463
RELEASED	DESCRIPTION
 Automated PACKAGING SYSTEMS 18175 PHILIPP PARKWAY - STEELESBORO, OH 44241	
FILE	FOOTPRINT, AB 550
DRAWING NO.	FP230
SHEET # OF #	A